

Saw Blades

For CleanCast™ saws

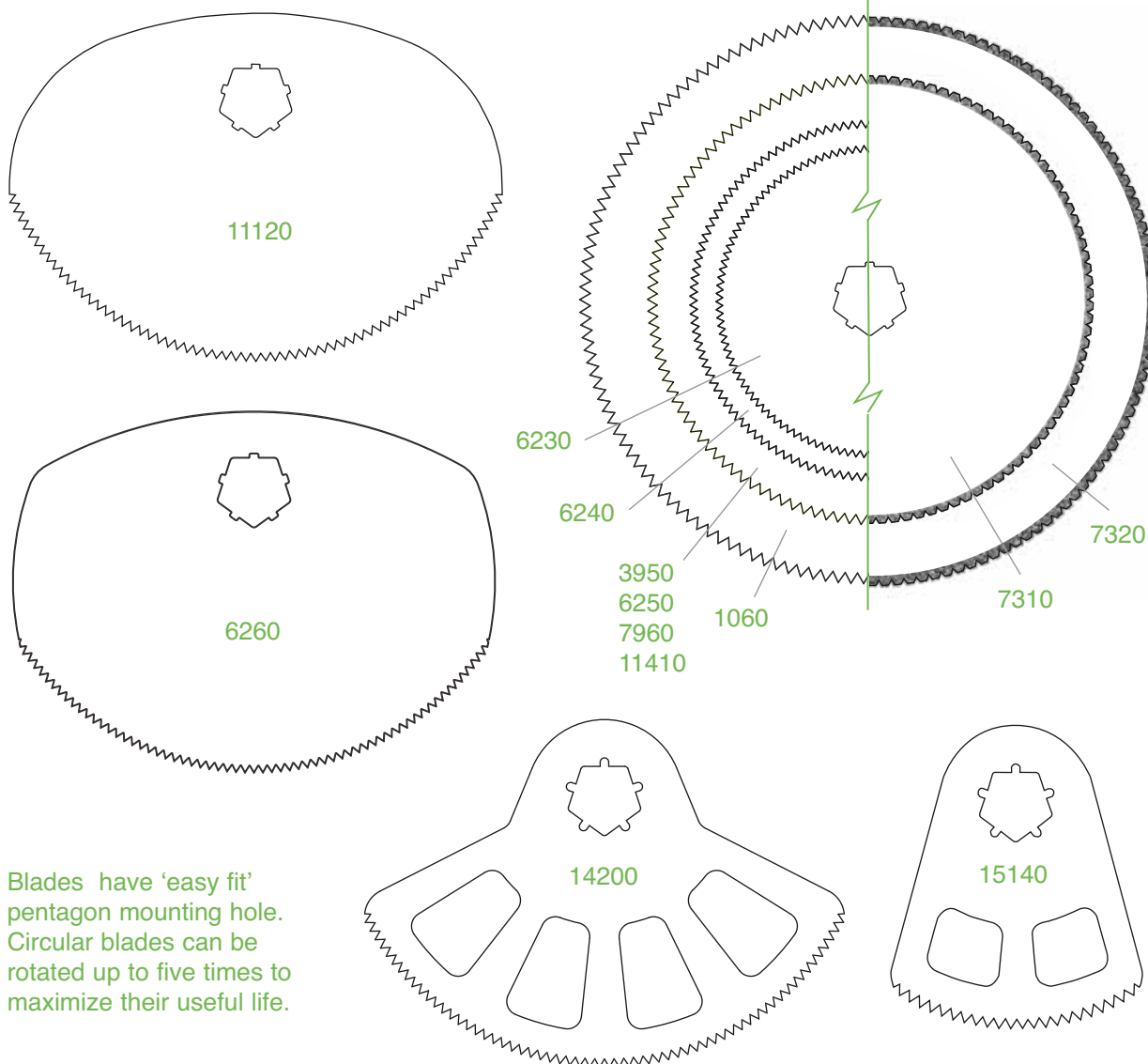

Blades have 'easy fit' pentagon mounting hole. Circular blades can be rotated up to five times to maximize their useful life.

Blade range/Part no. All blades are sold in boxes of 5.

Blade dia mm	Blade shape	Hard chrome PTFE coated	Stainless steel	Ion nitride	Titanium nitride	Diamond
44	Circular	6230				
50	Circular	6240				
64	Circular	6250	7960	11410	3950	7310
80	Circular	1060 ¹⁾				7320 ¹⁾
64	Segment		15140 ²⁾			
76	Segment		14200		11120	
80	Segment	6260				
POP - Gypsona		Optimal				
Fibreglass - Deltalite/Scotchcast		Suitable				
Polyester - Deltalite/Benicast/CellaCast		Not recommended				

¹⁾ Not suitable for Model CC5.

²⁾ Low noise/vibration blade - ideal for paediatric use.